

Model N-51 – 40 HP (29.83 kW)

DESCRIPTION The N-51 is a two-stage pressure regulator designed for sensitivity and simple operation. It is used with high pressure propane vapor in applications up to 40 HP (29.83 kW). Because of its compactness, it offers excellent results in most mobile equipment applications.

OPERATION LP-gas vapor enters the primary chamber and is then reduced from the tank pressure to about 4 psi (27.579 kPa).* As negative pressure is transmitted from the carburetor to the regulator, the regulator will allow fuel to be drawn into the carburetor. Some N-51 models are equipped with an idle circuit that allows for adjustment of the fuel mixture at low engine speeds. Some regulators are equipped with a primer button. Correctly installed regulator should not require priming. If priming is required, a maximum duration of only 1 second should be used.



CAUTION — INSTALLATION & SERVICE

Only trained, certified technicians should perform installation, service or replacement of fuel delivery components.



NOTE — NFPA CODES & STANDARDS

For indoor applications by NFPA definition, a regulator is not considered a positive shut-off valve. An approved automatic shut-off device is required to be installed. This will shut off the fuel supply should the engine fail while unattended. Shut-off devices come in vacuum- or solenoid-actuated configurations.

The internal lock off that overrides the idle circuit on some N-51 models is NOT considered a positive shut-off valve.

* Alternate primary pressure settings are available to meet engine displacement requirements, ranging from 2.5 psi to 4.5 psi (17.236 kPa to 31.026 kPa), in 0.5 psi (3.447 kPa) increments. To order primary pressure other than 4.0 psi (27.579 kPa) add as a suffix to the part number. Ex. N-51A-C-3.0

ORDERING INFO

Part No.	Idle Circuit	Internal Vacuum Lockoff	Primer	No. Of Mounting Ears	UL Listed*
N-51A	•	•		2	•
N-51A-C	•	•		1	•
N-51-1A		•	•	2	•
N-51-1A-C		•	•	1	•
N-51-2A	•	•	•	2	•
N-51-2A-C	•	•	•	1	•
N-51-3A			•	2	
N-51-3A-C			•	1	
N-51-4A				2	
N-51-4A-C				1	
N-51-5A	•			2	
N-51-5A-C	•			1	
N-51-6A	•		•	2	
N-51-6A-C	•		•	1	

U.L. Listed*

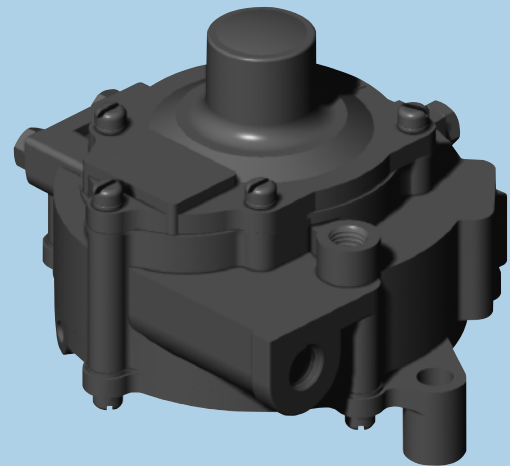

- LP vapor withdrawal regulator
- Primary pressure setting may be specified to meet engine displacement requirements
- Adjustable idle circuit with internal lock off available
- Ideal for indoor mobile maintenance equipment applications, small air-cooled engines, burners, saws, riding mowers

REGULATOR SPECIFICATIONS

- A. Overall Height 5 $\frac{3}{8}$ " (136.5mm)
- B. Overall Depth 3 $\frac{5}{8}$ " (92.1mm)
- C. Overall Width 5 $\frac{3}{8}$ " (136.5mm)
- D. Back of Regulator to Center of Vapor Fuel Inlet/Outlet . . 1 $\frac{5}{16}$ " (33.3mm)
- E. Mounting Holes Center 4 $\frac{3}{4}$ " To Center (2) Locations (120.7mm)
- F. Fuel Inlet NPT $\frac{1}{4}$ " (6.4mm)
- G. Vacuum Port NPT $\frac{1}{8}$ " (3.2 mm)
- H. Primary Test Port NPT $\frac{1}{8}$ " (3.2mm)
- J. Vent/Balance Line N/A
- K. Vapor Fuel Outlet NPT $\frac{3}{8}$ " (9.5mm)

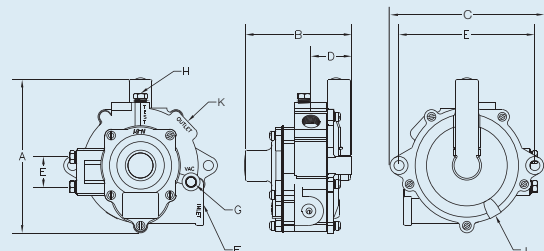

PARTS LISTING

Item	Part No.	Description	Qty.
1	N-C2-3	Cap, Tamper Resistant	1
2	N-R2-2	Retainer, Spring	1
3*	N-S2-5	SCREW, COVER, 10-32 X 5/8" SEMS	6 (RK 4)
3B*	N-S2-5T	SCREW, COVER, 10-32 X 5/8" TAMPER RESISTANT	4 (RK 2)
4	N-C1-4-1	Cover, Primary	1
5	N-S3-8	Spring, Primary	1
6*	N-G1-3	GASKET, PRIMARY	1
7*	N-D1-6A	DIAPHRAGM ASSEMBLY, PRIMARY	1
8	N-S2-4	Screw, Lever Bridge, 10-32 x 5/16" SLFH	2
9	N-B2-1	Bridge, Primary Lever	1
10	N-P1-5	Pin, Primary Lever	1
11*	N-L1-2	LEVER, PRIMARY	1
12*	N-V1-4	VALVE, SECONDARY SEAT	2
13	N-S3-7	Spring, Primary Lever	1
14	N00-6104	Plug, 1/8" NPT, Hex Head	1
15	N00-6402	Screw, 1/4-20 x 9/16" SEMS	2
16	N-B1-2A	Body Assembly	1
17	N-S3-9	Spring, Vacuum Lock	1
18*	N-D1-4A	DIAPHRAGM ASSEMBLY, VACUUM LOCK	1
19	N-R3-1	Ring, Vacuum Lock	1
20	N-S2-6	Screw, Vacuum Lock Ring, 10-32 x 3/8" Slotted Pan Head	4
21	N-S3-12-2	Spring, Secondary Lever	1
22	N-S2-10	Screw, Secondary Lever, 10-32 x 1/4" Slotted Pan Head	2
23*	N-L1-3A	LEVER ASSEMBLY, SECONDARY	1
24	N-P1-10	Pin, Secondary Lever	1
25*	N-D1-5A	DIAPHRAGM ASSEMBLY, SECONDARY	1
26*	N-C2-2	CAP, TAMPER RESISTANT FOR IDLE SCREW	1
27	N-S2-8	Screw, Idle Adjustment (Part of Item 28)	1
28	N-C1-5A	Cover Assembly, Secondary	1
	N-C1-5A-1	Cover Assembly, Sec., with Primer	
	N-C1-5A-C	Cover Assembly, Sec., One Mounting Ear	
	N-C1-5A-1C	Cover Assembly, Sec., w/ Primer, One Mounting Ear	

* Indicates Repair Kit Components

REPAIR KIT: (Components marked with (*) and shown in blue)
N-RK-51A

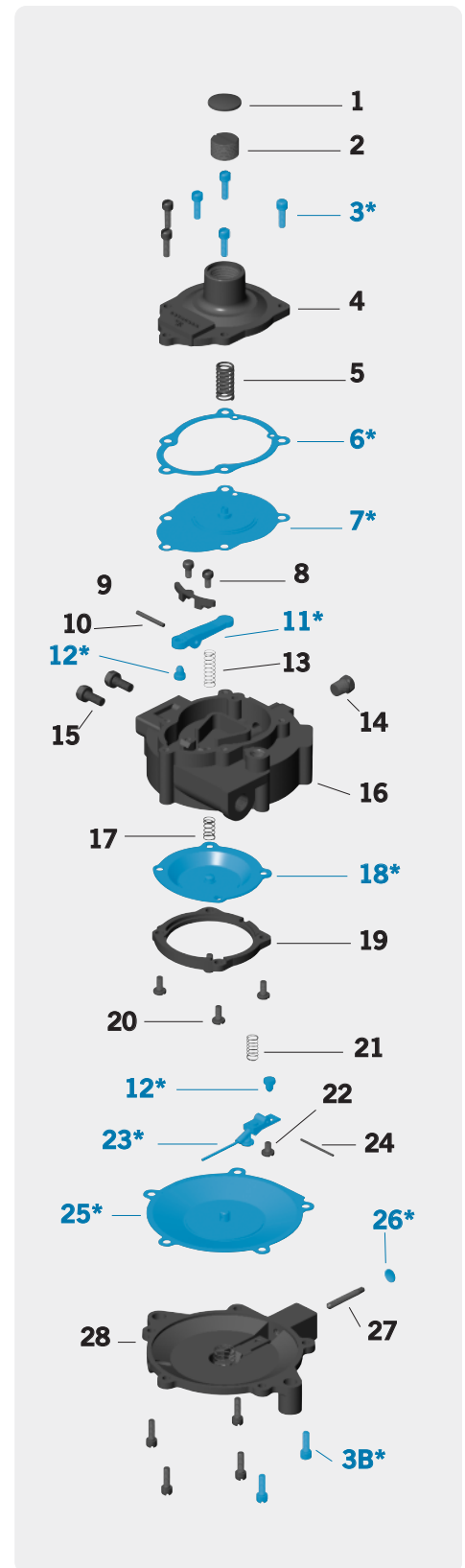

Note: Parts in blue are components of Repair Kit (N-RK-51A).

Note: While only certain parts are available for purchase, all parts are listed for reference purposes.