

Streamline™

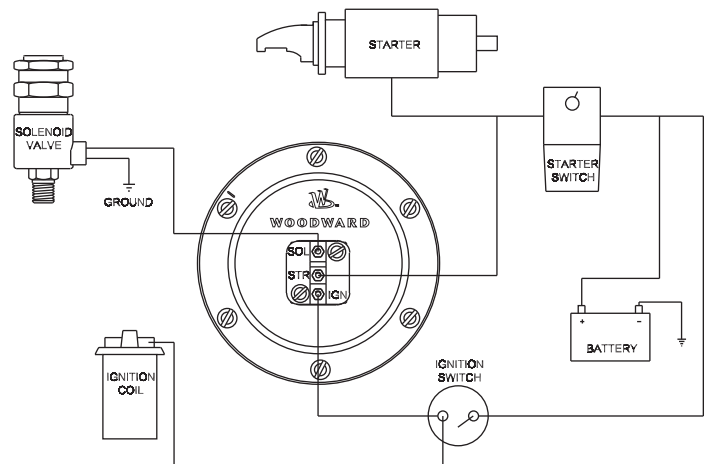
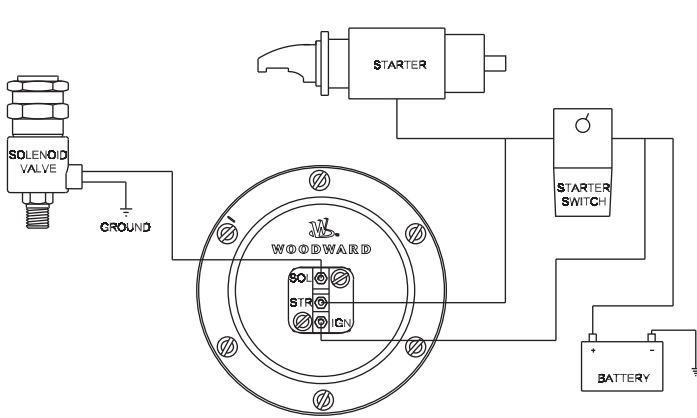
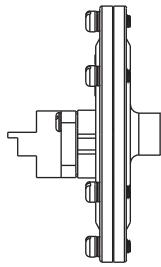
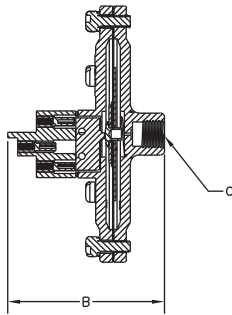
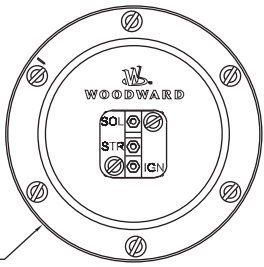
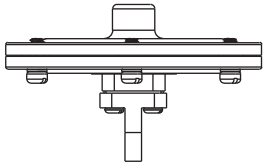
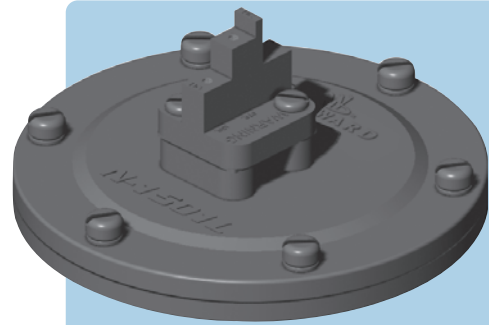

PART NO.	DESCRIPTION	DIMENSION A DIAMETER	DIMENSION B OVERALL WIDTH	DIMENSION C VACUUM PORT
N-1501L-A	Microvac Safety Switch	3-13/16" (96.84mm)	2-5/16" (58.74mm)	1/8" (3.2mm)

GENERAL

The Microvac switch provides immediate closing of points during starting. Maximum working pressure is about 30 inches of mercury vacuum. Maximum electrical rating is 12 Vdc @ 2A. Switch remains closed down to 1.5" of water column.

PART NO.	MODEL NO.	DESCRIPTION	QTY.
1	N-S10-8	Screw, 10-32 x 7/16" Slotted Fillister Head SEMS	6
2*	N-S10-9	SCREW, 8-32 X 7/16" SLOTTED FILLISTER HEAD	2
3	N-S10-11	Screw, #4-40 x 1/4" Slotted SEMS	3
4	N3-00076-1	Ring Terminal	3
5*	N-H10-1	SWITCH HOUSING	1
6*	N-S16-1	SWITCH, MICRO	1
7	N-G10-3	Gasket	1
8	N3-0012	Clamp	1
9	N-C10-5	Cover, Top	1
10*	N-S11-8	DIAPHRAGM ASSEMBLY	1
11*	N-S11-8	SPRING	1
12	N-C10-6	Cover, Bottom	1

* Indicates Repair Kit Components

REPAIR KIT

N-RKN1501LA

WARNING: Never short the Microvac terminals to ground. Microvac is a precision unit and will not withstand heavy surges of current that bypass the solenoid valve circuit.

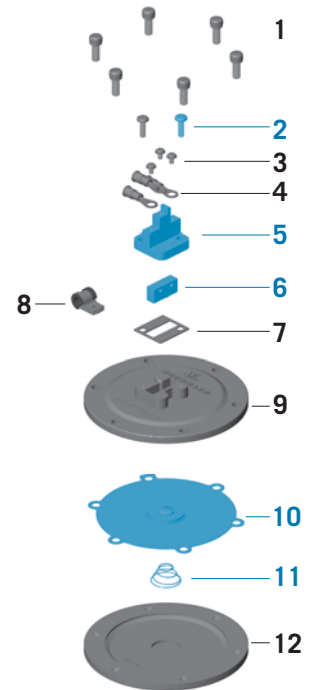

INSTALLATION

1. Install Microvac at any convenient source of manifold vacuum, away from the heat of the exhaust system.
2. Use 16-gauge primary automotive wire. Insulated terminals are provided. To avoid mistakes, connect one circuit at a time as follows:
3. Connect "SOL" (Solenoid) terminal of Microvac to electric solenoid valve or filter-lock.
4. Connect "IGN" (Ignition) terminal of Microvac to coil side terminal of ignition switch. If there is no bypass resistor in the ignition circuit, this wire may be connected to the battery terminal of the ignition coil.
For use as a 2-wire switch, simply do not connect the center terminal; use the two outside terminals only.
Proceed to Step 6.
For use as a 3-wire switch, proceed with Steps 5 and 6.
5. Connect center "STR" (Starter) terminal of Microvac to terminal on starter switch which goes to starter. Engaging starter will complete circuit to solenoid valve only while the starter is energized.
6. Secure all the electrical wires to the Microvac. After installation, remove one screw at the most convenient location, replace it with the longer screw and clamp provided. Run all wires through the clamp and tighten. This will avoid vibration at the terminals and extend their life.

OPERATION

2-Wire Installation: Start engine on a closed throttle or use a pumping action to allow the throttle to close momentarily to build up manifold vacuum to close the normally open circuit ("IGN" to "SOL"). Solenoid valve will remain open as long as the manifold vacuum is present.

3-Wire Installation: Normally, the engine will start at any throttle position. The normally closed circuit (Step 5, "STR" to "SOL") will automatically open to avoid current feedback after the engine starts.

SERVICE

If the unit requires service, we suggest you take it to a qualified service technician. If not available, Woodward will furnish you a list of repair facilities or provide service information.

Note: While only certain parts are available for individual purchase, all parts are listed for reference purposes.